

Application of TRMM Data to the Analysis of Water Availability and Flood Discharge in Duriangkang Dam

Willy*, Bambang Adi Riyanto, Doddi Yudianto, Albert Wicaksono

Department of Civil Engineering, Parahyangan Catholic University

*Corresponding authors: willyau.95@gmail.com

SUBMITTED 15 November 2019 **REVISED** 3 December 2019 **ACCEPTED** 6 January 2020

ABSTRACT One of the challenges in hydrologic modelling in Indonesia is data limitation. Rainfall data quality is rarely evaluated, and in some cases, the data are unavailable. The Tropical Rainfall Measuring Mission (TRMM), satellite rainfall data provided by NASA, is an alternative method to solve such problems. This study aims to promote the use of TRMM data to analyze water availability and flood discharge in Duriangkang Dam, Batam City, Indonesia, in comparison with the use of available ground station data. Results show that the ground station data contain some errors; however, overall, the data show similar patterns and acceptable differences compared with the TRMM data. The NRECA and HEC-HMS models are used to analyze water availability, and both models are calibrated using the available reservoir water level data. The NRECA model generally shows a good fit of monthly discharge, although the use of TRMM results in slightly overestimated values in dry years. Similar results are obtained for daily discharge computation using the HEC-HMS model. Water availability analysis using the TRMM data shows an acceptable margin of error. When flood discharge is computed using an uncalibrated HEC-HMS model, the TRMM data somehow yield a lower maximum daily rainfall value than the ground station data. As a result, the obtained 10,000-year flood calculated using the Hang Nadim Station and TRMM data are 1,086 and 624 m³/s, respectively. Therefore, the use of corrected TRMM data in flood discharge computation is essential but increases the value up to 897 m³/s.

KEYWORDS TRMM; Water Availability Analysis; Flood Discharge Computation; Duriangkang Dam

© The Author(s) 2020. This article is distributed under a Creative Commons Attribution-ShareAlike 4.0 International license.

1 INTRODUCTION

1.1 Background

The hydrologic analysis relies on data availability. Problems occur when the data of some countries, such as Indonesia, are limited. Most of the time, discharge data are unavailable, whereas rain gauge data are few. Moreover, the data quality is poor, and rainfall is not distributed evenly on the basin. In some cases, rain gauge data are even unavailable. A possible solution to the rainfall data problem is the use of satellite rainfall data.

Launched on November 27, 1997, the NASA Tropical Rainfall Measuring Mission (TRMM) is a joint US-Japan satellite mission to provide the first detailed and comprehensive dataset of the four-dimensional distribution of rainfall and latent heat over vastly undersampled tropical and subtropical oceans and continents. TRMM 3B42 data are available at a temporal resolution of 3 h and a spatial resolution of 0.25° × 0.25°, with

area-averaged rainfall value (Huffman, Pendergrass and National Center for Atmospheric Research Staff (Eds), 2019). A previous study showed that the TRMM data are better than the monthly PERSIANN and CMORPH data of Indonesia, but it still has deviations compared with the ground station data (Vernimmen et al., 2012). The error can be overestimated or underestimated, depending on the area (Mamenun, Pawitan and Sophaheluwakan, 2014; Hur et al., 2016; Tan and Duan, 2017; Sofiati and Avia, 2018). Therefore, the TRMM data need to be corrected before being used for further analysis.

1.2 Duriangkang Dam

This study focuses on Duriangkang Dam located in Batam City, Indonesia. Batam City exhibited economic growth in the 1990s, drawing more people to live in this city. As a result, the water demand in the area increased and the city needed



Figure 1. Locations of (a) Duriangkang Dam and (b) Duriangkang Dam Basin and rainfall gauge

sufficient water supply to support its development (Indonesia–Malaysia–Thailand Growth Triangle, 2016). However, water availability was limited because Batam City is located on an island, as shown in Figure 1(a). To address this problem, the authorities of Batam City constructed several reservoirs to accommodate the water demand in the area. Duriangkang Dam was one of these reservoirs and was built in cascade with Mukakuning Dam. Different from other reservoirs, Duriangkang

Dam was constructed near the seashore, which made it the first and largest estuary dam in Indonesia. With a capacity of 107 million m^3 , Duriangkang Dam provides clean water for the city through two water treatment plants with capacities of 2.2 and 0.3 m^3/s , respectively (CDPP Consortium, 1991).

1.3 Problem Identification

Around the Duriangkang Dam Basin, only two rain gauge stations, namely, Duriangkang and Hang Nadim Station, are found. As shown in Figure 1(b), Duriangkang Rain Gauge Station is located near the dam, whereas Hang Nadim Rain Gauge Station is located outside of the basin. This location is not ideal because the regional rainfall of Duriangkang Dam Basin cannot be presented well.

Meanwhile, the data from Duriangkang Rain Gauge Station have a large number of empty data;

thus, it cannot be used for continuous analysis. The data from Hang Nadim Rain Gauge Station also have some empty data and an error in the form of small rainfall values in 2012 and 2013, as shown in Figure 3 (Yudianto, Willy and Riyanto, 2019). For the study location, the TRMM data available is on one grid, with its Centerpoint at longitude 104.125° and latitude 1.125° . The TRMM rainfall data used in this study span from 1998 to 2018.

This study aims to analyze and compare water supply and flood discharge using available ground station data, TRMM data and corrected TRMM data. This study also aims to provide an overview of the usage of TRMM data compared with ground station data in cases where the data have error or are unavailable.

2 METHODS

To achieve its objective, this study was conducted through several stages, as follows: (1) comparison of TRMM and ground station data to check the correlation between the two datasets; (2) correction of the TRMM data to reduce the error compared with the ground station data; (3) use of continuous monthly data for both daily and monthly water supply analyses; and (4) use of maximum daily rainfall for both rainfall and flood design analyses. The analysis will be conducted using ground station data, uncorrected TRMM data, and corrected TRMM data.

2.1 Duriangkang Dam Basin

The Duriangkang Dam Basin is shown in Figure 1(b). With an area of 75.18 km², it is one of the largest in Batam Island. Upstream of the Duriangkang Dam, the smaller Mukakuning Dam, with a basin area of 9.64 km², is located. Given that there is no recorded data on spilled water discharge from Mukakuning Dam, this study assumed that all runoff water from Mukakuning Dam is used for water supply through the Mukakuning Water Treatment Plant. This assumption may make the calibration result of the loss subcomponent of the basin smaller than that of the actual condition.

On the basis of 2018 measurements, the dam itself has 100.2 million m³ of live storage compared with 107 million m³ of the design. The reservoir area is 25 km², which is 31% of the basin area. Meanwhile, the dam height is only 15 m. The reservoir is surrounded by protected forest, which covers 55% of the Duriangkang Dam Basin. Meanwhile, 14% of the basin is considered residential and industrial areas in the northern and eastern parts of the basin (PT. Caturbina Guna Persada, 2018).

2.2 Water Availability Models

2.2.1 NRECA model

The NRECA model is selected in this case as it is one of the most often used models in water supply analysis in Indonesia. The NRECA model was developed by Crawford to calculate the monthly runoff from a mini-hydropower system. The scheme of the NRECA model shown in Figure 2 is divided into two types of storage, namely, moisture storage and groundwater storage. The excess from the moisture storage is discharged to either groundwater or direct flow, depending on the PSUB parameter. The groundwater flow/baseflow is determined on the basis of the groundwater storage and the GWF parameter. Both PSUB and GWF parameters should be calibrated (Fritz, 1984). In this case study, the calibration is conducted using available reservoir water level data.

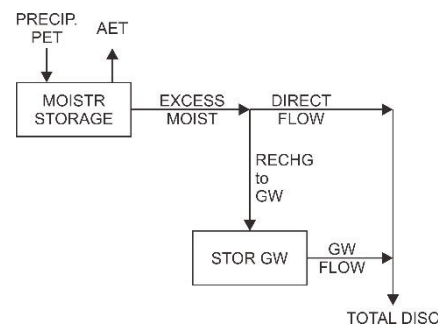

Figure 2. Scheme of the NRECA model

Then, the discharge calculated using the NRECA model is utilized for reservoir simulation, which is conducted using the basic mass conservation equation. Equation (1) can be solved using the inflow, outflow, and reservoir characteristics as the inputs.

$$I - O = \frac{\Delta S}{\Delta t}, \quad (1)$$

where I is the inflow (m³/s), O is the outflow (m³/s), ΔS is the change in storage (m³), and Δt is the time interval. The inflow consists of the river discharge calculated using the NRECA model and rain on the reservoir area, whereas the outflow consists of the water supplied to the WTP, evaporation from the water body, and spilled water if the reservoir water level is above the spillway elevation. The data for discharge water supplied to the WTP is unavailable in this study; thus, it is assumed that the WTP is working at full capacity all of the time, with a discharge of 2,500 L/s.

2.2.2 HEC-HMS model

In the HEC-HMS model, the Duriangkang Dam is simulated as a single basin. The loss subcomponent is calculated using the deficit and constant method, the transform subcomponent is calculated using the SCS unit hydrograph, and the baseflow subcomponent is calculated using the recession method. The parameters of the loss and baseflow subcomponents are obtained from the calibration. The lag time parameter of the SCS unit hydrograph is calculated using the Kirpich method, and the resulting lag time is 355 min. This lag time is smaller than the simulation time interval of 24 h; therefore, it will not affect the

calculation. The loss from evaporation is inputted into the meteorological model.

2.3 Flood Design Analysis

Frequency analysis of the rainfall design is conducted using the Gumbel-1 probability distribution. The probable maximum precipitation (PMP) is calculated using the Hershfield method. The rainfall design will be used in flood discharge analysis, which utilizes the HEC-HMS model. The HEC-HMS model for flood discharge analysis uses the SCS curve number for the loss subcomponent, the SCS unit hydrograph for the transform subcomponent, and a constant baseflow. The discharge will be calculated on the basis of the 10,000-year return period, which is one of the design criteria of the dam, and the probable maximum flood (PMF) condition.

3 RESULTS AND DISCUSSION

3.1 Rainfall Data Analysis

Rainfall on Batam City, based on the collected data, does not follow the seasonal pattern. Rain may come any month of the year, although November and December have the highest average monthly rainfall. The average annual rainfall in Batam City is 2,272 mm according to the Hang Nadim Station data reported by the Meteorological, Climatological, and Geophysical Agency (BMKG). The TRMM data indicate a slightly higher value, at 2,409 mm.

First, the monthly rainfall data are compared. Figure 3 shows a comparison of the three available datasets. The correlation coefficient between TRMM and Hang Nadim Station data is 0.79, indicating that the rainfall pattern between the two datasets is good. With the Duriangkang Rain Gauge Station having a large number of empty data, the pattern of the two datasets is still acceptable, with a correlation coefficient of 0.67.

The error of the three datasets, calculated using the root mean square error (RMSE), is 81 mm for the TRMM and Hang Nadim Station data and 92 mm for the TRMM and Duriangkang data. The most noticeable error, as shown in Figure 2, is

that of the Hang Nadim rainfall value in 2012 and 2013, which is considerably small. In 2015–2017, the January data of Hang Nadim Station is always 0. For continuous analysis, the ground station data will be combined, with the Hang Nadim Station data as the main dataset and the Duriangkang data as the error data.

Then, the TRMM data are corrected using a multiplication factor to reduce the RMSE. The factor increases the rainfall value during wet months and decreases the rainfall value during dry months. The rainfall value between 0 mm and 20 mm is multiplied by 1, that between 20 mm and 150 mm is multiplied by 0.91, that between 150 mm and 300 mm is multiplied by 0.9, and that greater than 300 mm is multiplied by 1.1. As a result, the RMSE is decreased to 77 mm and the correlation coefficient is increased to 0.8. Thus, the annual rainfall is 2,283 mm, which is close to that of the Hang Nadim Station.

The annual maximum daily rainfall data, which will be used for flood design, shows a more significant difference than the continuous data. The TRMM data show a generally smaller value, particularly in the years 2002–2007 and 2011 as shown in Figure 4.

The correlation between Hang Nadim Station and TRMM maximum daily rainfall is 0.66, with the RMSE of 61 mm. Correction with the multiplication factor of 1.4 can reduce the RMSE to 51 mm.

3.2 Water Availability Model

The NRECA model using the three datasets is calculated using the same parameters. The result of synthetic discharge calculated using the TRMM data shows a generally larger value than the ground stations. The water level shown in Figure 5 indicates that the pattern of the three calculated discharge value is similar. The difference between the two datasets on average is quite small, only 0.23 m³/s or 9%. The difference can be detected in smaller discharge, wherein the 95% dependable discharge, the TRMM data result in twice larger discharge than the ground station data, as shown in Table 1. Correction of the TRMM data is able to

reduce the overestimated discharge but is unable to well simulate the drought in 2015–2016. The average and 50% dependable discharge calculated using the corrected TRMM data are lower than that using the ground station data.

Similar to the monthly NRECA model result, the daily HEC-HMS model result obtained using the TRMM data shown in Figure 6 shows a higher water level in 2014 and 2015 and an early increase in the water level in 2016.

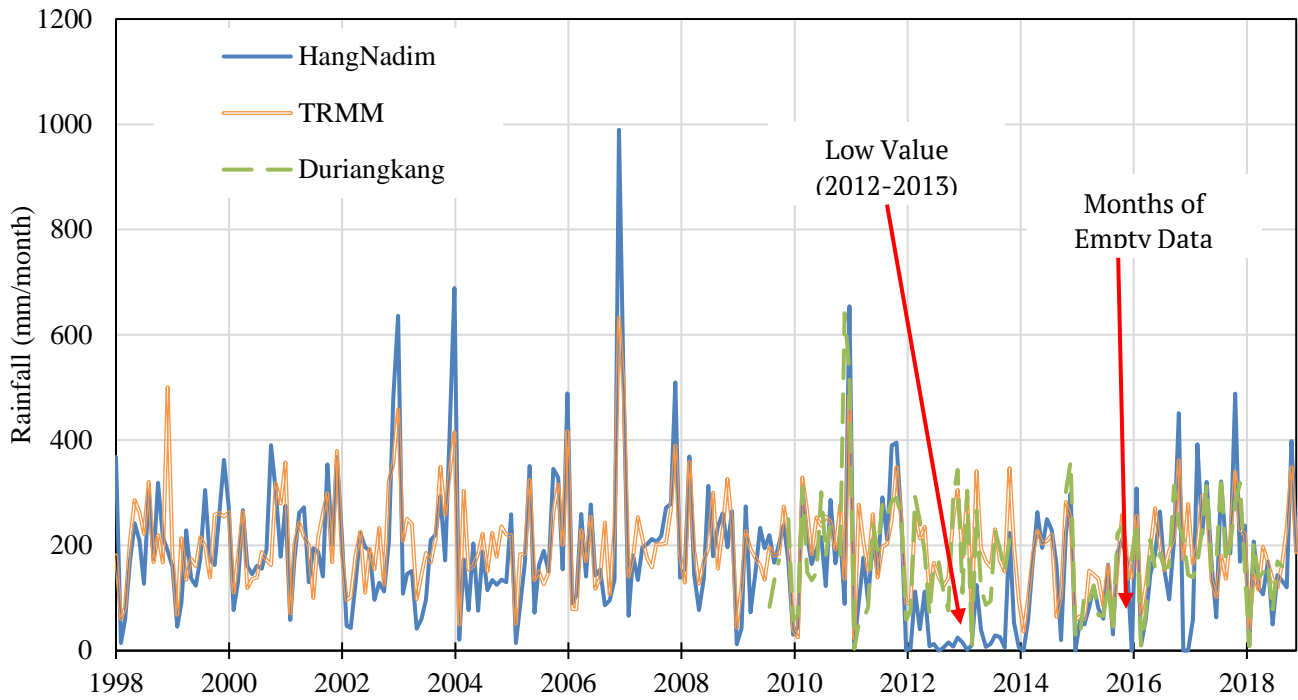

Figure 3. Monthly rainfall data

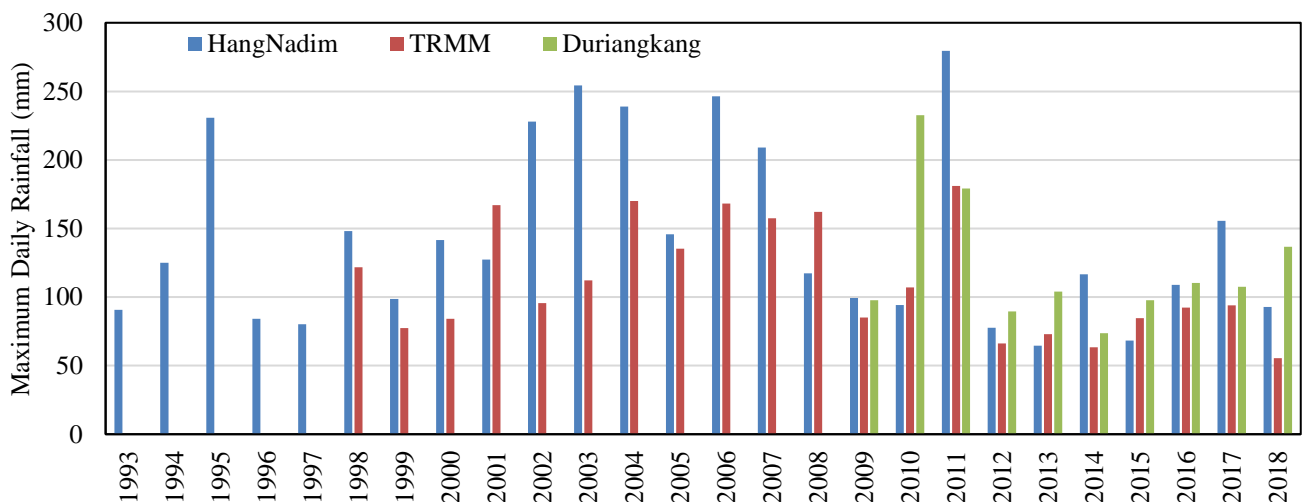

Figure 4. Annual maximum daily rainfall

3.3 Flood Design Analysis

The noticeable difference in the maximum daily rainfall series results in a significant difference in rainfall design. The 10,000-year return period rainfall calculated with the Gumbel-1 probability distribution using the Hang Nadim Station data is 665 mm, whereas using the Duriangkang data is 565 mm. Using the TRMM data, the rainfall design is only 443 mm, i.e., 33% smaller than that using

the Hang Nadim Station data. The PMP calculated with the Hershfield method is 1,019 mm for the Hang Nadim Station data (Wicaksono, Willy and Riyanto, 2018) and only 654 mm for the TRMM data, i.e., 36% smaller. The difference can be reduced after correcting the TRMM data and increasing the 10,000-year return period rainfall to 574 mm, thus increasing the PMP rainfall to 898 mm and decreasing the difference to only 12% to 14%.

Table 1. NRECA monthly discharge comparison

Discharge (m ³ /s)	Ground stations	TRMM	Corrected TRMM
Q _{average}	2.3	2.53	2.25
Q _{50%}	1.95	2.26	1.84
Q _{80%}	0.82	1.1	0.88
Q _{90%}	0.58	0.81	0.59
Q _{95%}	0.32	0.64	0.46

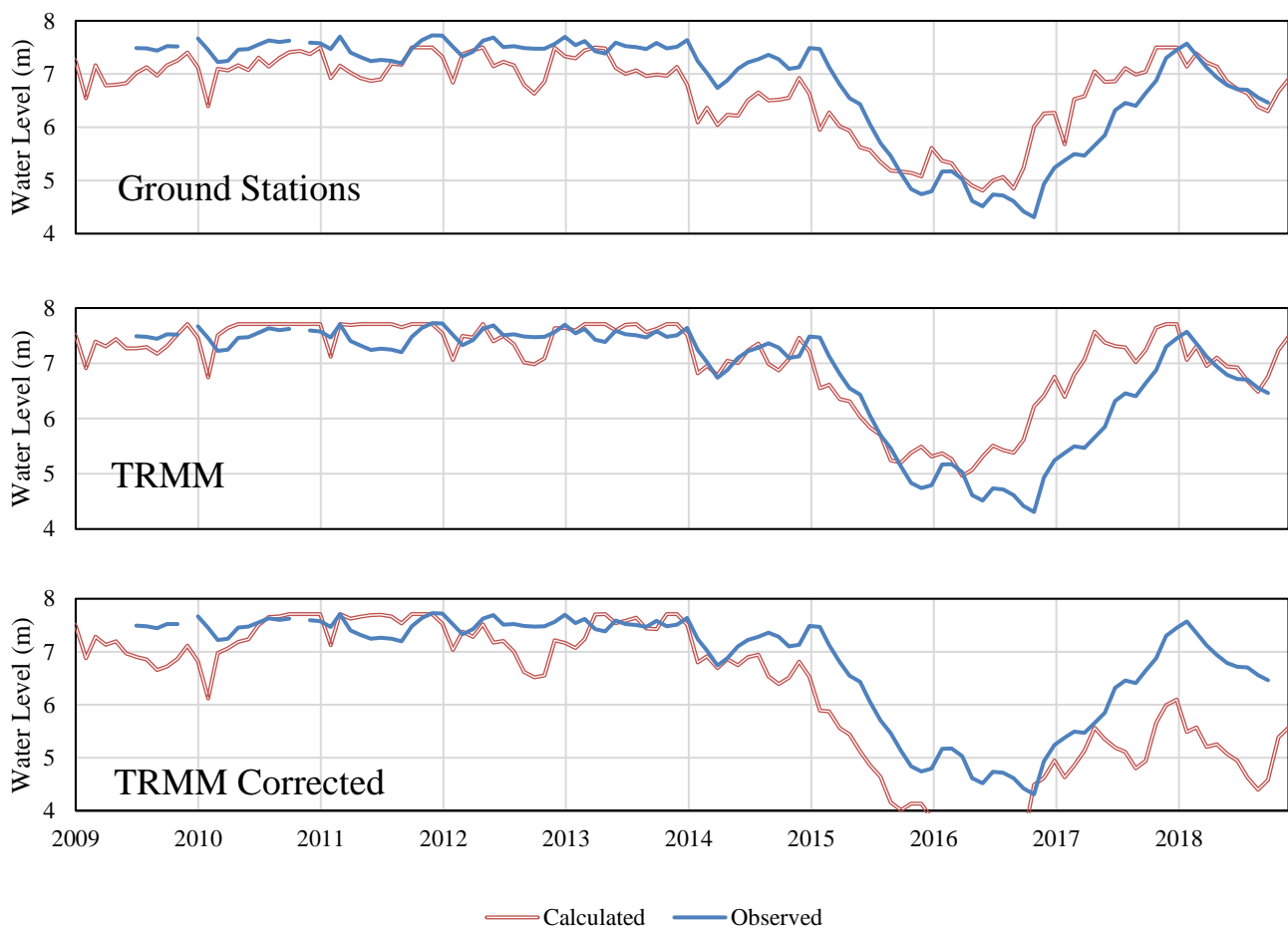

Figure 5. Comparison of the water level using the monthly model

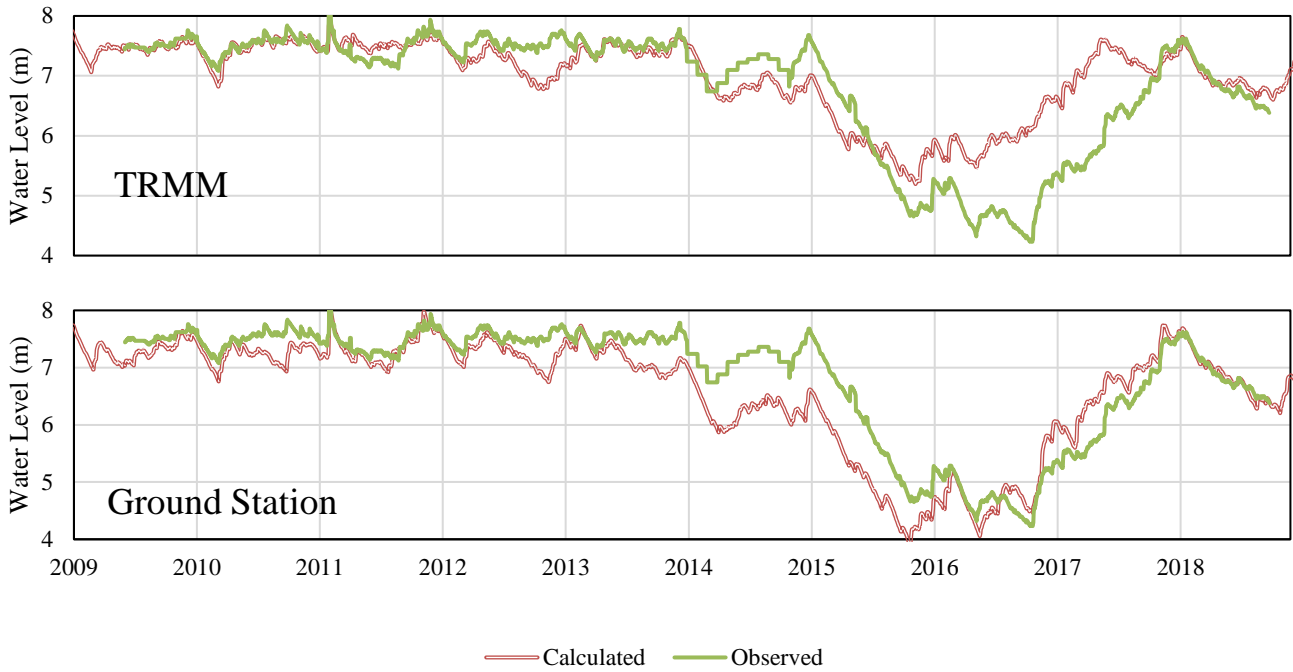

Figure 6. Comparison of the water level using the daily model

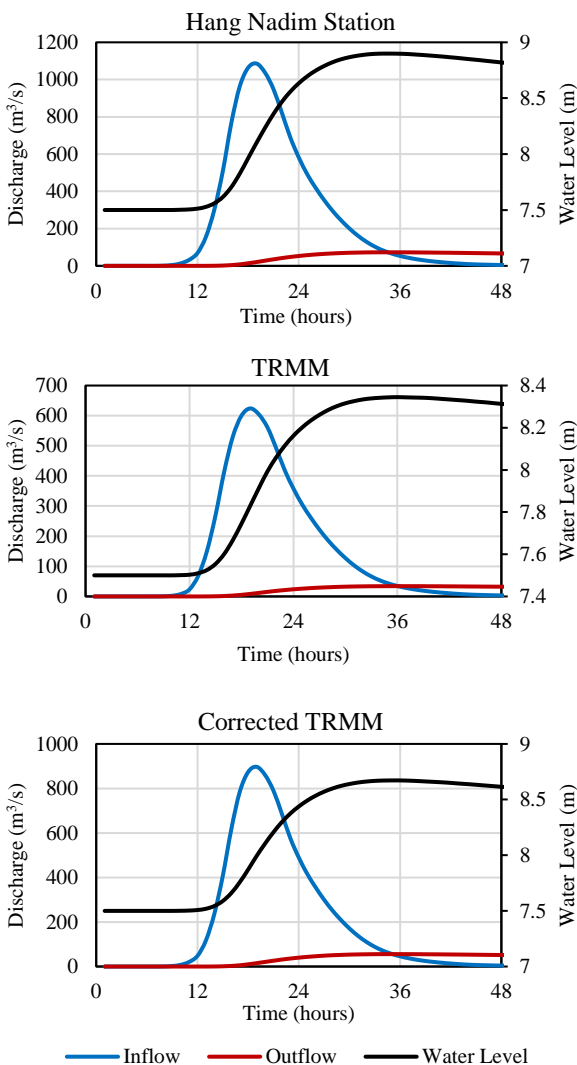

Figure 7. Flood discharge and routing

The flood discharge difference between TRMM and Hang Nadim Station data is quite significant, as shown in Table 2 and Figure 7. The 10,000-year return period discharge from the TRMM data is only 624 m³/s, i.e., 43% smaller than that from the Hang Nadim Station data (1,086 m³/s). A similar difference is also detected in PMF and 0.5 PMF analyses. The discharge difference affects the maximum water level in the reservoir. Under the PMF condition, using the Hang Nadim Station data, the remaining freeboard from the dam crest (+10 m) is only 26 cm. Meanwhile, using the TRMM data, the remaining freeboard is 1.13 m.

Thus, correction of the TRMM data is essential in flood design analysis. Correction of the TRMM data results in an increase so that the 10,000-year return period discharge is 897 m³/s or only 17% smaller than that of the ground station data. The remaining freeboard also decreases to 55 cm.

Table 2. Flood design result summary

Rainfall data	Return period	Inflow (m ³ /s)	Outflow (m ³ /s)	Water level (m)
Hang Nadim	10,000 years	1086.0	72.8	8.90
	0.5 PMF	901.2	57.2	8.69
	PMF	1825.6	147.0	9.74
TRMM	10,000 years	624.1	34.2	8.35
	0.5 PMF	522.4	26.9	8.22
	PMF	1065.1	70.9	8.87
Corrected TRMM	10,000 years	897.2	55.8	8.67
	0.5 PMF	774.8	46.3	8.54
	PMF	1571.2	120.0	9.45

4 CONCLUSION

This study showed that the TRMM 3B42 data can be used for water supply continuous analysis and obtains a good result, albeit slightly overestimating values in dry years. The TRMM data can be used as a comparison or even a substitute when ground station data are unavailable or have an error, such as in the 2012–2013 Hang Nadim Station data in this case. Correction can increase the accuracy of the data. However, as shown in the case of dry years, correction can also reduce accuracy. Correction of the TRMM data is essential in flood design analysis as the result is 47% smaller than that of the Hang Nadim Station data. The correction factor of 1.4, specific for this case, can reduce the error to only 17%.

DISCLAIMER

The authors declare no conflict of interest.

ACKNOWLEDGMENTS

The authors would like to thank BBWS Sumatra IV, BP Batam, and Adhya Tirta Batam for providing the data available for this study.

REFERENCES

- CDPP Consortium, 1991. *Duriangkang Water Supply Scheme*.
- Fritz, J.J., 1984. *Small and Mini Hydropower Systems*. McGraw-Hill.
- Huffman, G.J., Pendergrass, A. and National

Center for Atmospheric Research Staff (Eds), 2019. *The Climate Data Guide: TRMM: Tropical Rainfall Measuring Mission*.

Hur, J., Raghavan, S. V., Nguyen, N.S. and Liong, S.Y., 2016. Evaluation of High-resolution Satellite Rainfall Data over Singapore. *Procedia Engineering*, 154, pp.158–167.

Indonesia–Malaysia–Thailand Growth Triangle, 2016. *Green City Action Plan City of Batam*.

Mamenun, Pawitan, H. and Sophaheluwakan, A., 2014. Validasi dan koreksi data satelit TRMM pada tiga pola hujan di Indonesia (Validation and correction of TRMM satellite data on three rainfall patterns in Indonesia). *Jurnal Meteorologi dan Geofisika*, 15(1), pp.13–23.

PT. Caturbina Guna Persada, 2018. *Final Report of Special Study of Duriangkang Dam*.

Sofiati, I. and Avia, L.Q., 2018. Analysis of Rainfall Data based on GSMaP and TRMM towards Observations Data in Yogyakarta. *IOP Conference Series: Earth and Environmental Science*, 166(1).

Tan, M.L. and Duan, Z., 2017. Assessment of GPM and TRMM precipitation products over Singapore. *Remote Sensing*, 9(7).

Vernimmen, R.R.E., Hooijer, A., Mamenun, Aldrian, E. and Van Dijk, A.I.J.M., 2012. Evaluation and bias correction of satellite rainfall data for drought monitoring in Indonesia. *Hydrology and Earth System Sciences*, 16(1), pp.133–146.

Wicaksono, A., Willy and Riyanto, B.A., 2018. *Evaluation of Capacity of Duriangkang Estuary Dam to Control Flood Flow.*

Yudianto, D., Willy and Riyanto, B.A., 2019. *Management of Estuary Dam of Duriangkang to Enhance Water Security in Batam City R2.*

[This page is intentionally left blank]